

**Integrated Expansion Unit (REG Unit)
of S10F/S10H (SVTU-10M (M1, M2) RP) heat&water
meter**

Operating Manual

(Part 2)

Content

1.	Introduction.....	4
2.	Purpose.....	4
3.	Technical Data	4
4.	Completeness	5
5.	Design and operation of the REG unit.....	5
6.	Preparing for operation	14
7.	Manufacturer's warranties.....	15

Appendixes

1. Introduction

1.1. This operating manual (hereinafter referred to as the OM) is a supplement to the operating manual for the S10F/S10H (SVTU-10M) heat&water meter, modifications (M1, M2) RP (hereinafter referred to as the meter) and contains information on the purpose and operation of the integrated expansion unit (REG) of the SVTU-10M heat&water meter.

1.2. Due to ongoing work aimed at expanding the functionality, improving technical characteristics and increasing the reliability of meters, the manufacturer, SEMPAL Co. LTD, reserves the right to make design changes not described in this Operating Manual.

1.3. For all questions related to the purchase, installation, operation and maintenance of meters, you can contact either SEMPAL Co. LTD directly or our authorized regional representatives.

**LLC FIRM “SEMPAL Co LTD”,
11, René Descartes str., Kiev, Ukraine, 03062**

Тел.: +38 (044) 3371188, (044) 3551188

+38 (098) 1638888, (050) 1428888

info@sempal.com

www.sempal.com.

2. Purpose

2.1. The REG unit is built into the SVTU-10M calculator by special order. The unit is designed to send signals to recording devices and create various control systems.

3. Technical Data

3.1. By agreement with the customer, the heat meter can be equipped with a built-in REG unit. The presence of the **REG** unit allows for the connection of additional recording or control equipment .

3.2. The REG unit has four channels (outputs). Two channels have an analog proportional output signal (linear outputs), and the third and fourth channels are used as key outputs.

The operating mode of each output is set via the REG control menu.

3.2.1. Linear outputs can be potential (generating a voltage at the output) or current (generating a current at the output). The user selects the output type (independently for each output) – current or potential – from the meter menu.

For each linear output, the minimum and maximum voltage (current) values at the output are set. For voltage outputs, these values range from 0 to 10 V, and for current outputs, from 0 to 20 mA.

The given error of the potential output with a load resistance of more than 20 kOhm does not exceed 1%. The output resistance of the potential outputs is 20 Ohm, the maximum load current is 10 mA .

The given error of the current output with a load resistance of no more than 500 Ohm does not exceed 1 %.

3.2.2. Each of the key outputs can be configured as either an active output or an open collector output .

The active output provides the following signal parameters:

- state “0” - current up to 20 mA at voltage not exceeding 0.2 V;
- state “1” – voltage 15 V (14 V and higher) at current up to 10 mA.

The open collector output can handle voltages up to 40 V and current up to 20 mA.

3.2.3. Each of the linear outputs can operate in three modes:

- linear;
- threshold;
- regulator.

Key outputs can only operate in threshold mode .

3.2.4. B In the control mode, the REG unit implements a proportional-integral control law (“PI”) with user-settable values of the time constant and the control channel transmission coefficient.

The setting range of the controller time constant value is from 0 s to 9999 s, resolution is 1 s.

The range of setting the regulator transmission coefficient is from 0 to 999.99 with a resolution of 0.01.

4. Completeness

4.1. External devices are connected to the unit's outputs via the switching unit included with the general-purpose cable. The switching unit's contact assignments are provided in Appendix A.

Depending on the order, the kit may also include cables for connecting the switching unit to the end devices.

5. Design and operation of the REG unit

5.1. The operating principle of the REG unit is based on the analysis of information about the value of informative parameters measured by the meter and the generation of signals at the outputs (channels).

The REG unit receives information from the meter at intervals of 1 s.

A description of the meter menu for setting the parameters of the REG unit is given in Appendix C .

5.2. Linear outputs

Each of the two linear outputs can be configured independently of the other one.

The following parameters are set :

- voltage/current – potential or current output;
- output type – linear/threshold/regulator;
- minimum – minimum output signal value;
- maximum – maximum output signal value.

After setting these parameters, the output signal will be able to change in the range from the minimum to the maximum value, without going beyond their limits.

For example, if the voltage output is set to a minimum of 2 V and a maximum of 10 V, then even in threshold mode the voltage of state “0” will be 2 V and the voltage of state “1” will be equal to 10V.

5.3. Key outputs

Key outputs can only operate in threshold mode.

Each output can be configured as an active output or an open-collector output.

For an active output, the "1" state is equivalent to an output voltage of 15 V with a maximum current of 10 mA. The "0" state is an output voltage of 0 V with a maximum current of 20 mA.

For an open collector, state "1" is the switched-on key with a maximum switching current of 20 mA, state "0" is the open key with a maximum output voltage of up to 40 V .

5.4. The purpose and operating modes of each channel are set (configured) by the user.

Каждый Each of the two linear channels of the REG block can be configured to operate in one of three modes, which determine the mode (type) of a given channel: "Linear," "Threshold," or "Regulator." Depending on the set type, the following output signals are generated at the corresponding REG outputs:

- Output signals Y, proportional to the informative parameters X, measured by the meter (output type is "Linear", dependence $Y(X)$ is linear function).
- Threshold output signals Y based on the results of comparison of the measured parameters X with the specified threshold values X_{ON} and X_{OFF} (output type is "Threshold").
- Output signals Y_i for controlling control valves (output type is "Regulator", number of valves is from one to two).

The key channels of the REG unit always operate in the "Threshold" mode.

5.5. «Linear» output type

(generation of signals proportional to the measured parameters)

This output type is only applicable for linear outputs.

5.5.1. The operation of the REG in the mode of generating output signals proportional to the measured parameters is illustrated by the structural diagram given in Fig. 5.1.

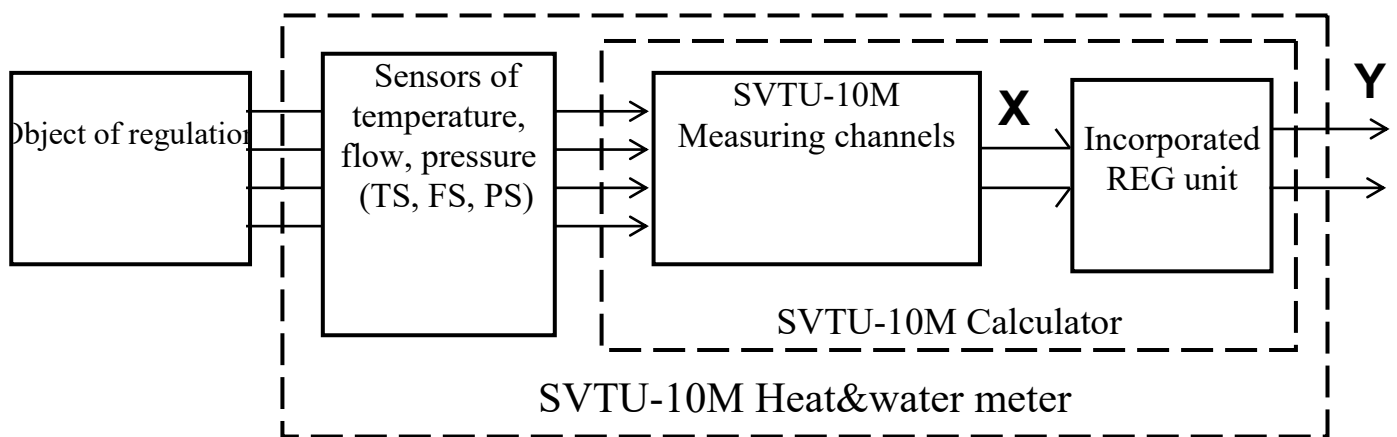

Fig. 5.1

The meter, based on the analysis of signals received from temperature sensors TS, flow rate FS and pressure PS installed at the facility, measures the specified informative parameters X (T_1, T_2, T_3, T_4, T_5 and P_1, P_2 are the values of temperatures and pressures measured by the corresponding sensors, Q_1 and Q_2 are the volumetric flow rates along the first and second channels of the meter, respectively).

The REG unit, based on information about the value X, generates a linearly changing signal Y at the corresponding current or potential output:

$$Y = A + B \cdot X = Y_{\min} + \frac{Y_{\max} - Y_{\min}}{X_{\max} - X_{\min}} \cdot (X - X_{\min}) \quad (5.1)$$

where X is the current value of the informative parameter measured by the meter;

Y is the current value of the signal at the corresponding REG output;

A and B are coefficients describing a linear relationship $Y(X)$;

X_{\min} and X_{\max} are minimum and maximum values of parameter X (entered by the user when configuring REG channels).

Y_{\min} и Y_{\max} are minimum and maximum values of the signal at the output of the corresponding REG channel. The values of Y_{\min} and Y_{\max} are determined by the user-selected output signal measurement range.

Thus, to set up a channel in linear mode, you need to set the following parameters:

- select the measured parameter – parameter type and channel (for example, type – RTD, channel 4 means RTD4);

- minimum and maximum value of the input parameter

- minimum and maximum value of the output signal

When selecting the inverse conversion characteristic, the output signal is described by the following expression:

$$Y = A + B \cdot X = Y_{\max} + \frac{Y_{\min} - Y_{\max}}{X_{\max} - X_{\min}} \cdot (X - X_{\min}) \quad (5.2)$$

5.6. «Threshold» output type

(generation of threshold output signals)

This output type applies to all outputs.

In this mode, the channel operates as a comparator of the measured X parameter with specified values of the on threshold X_{ON} and the off threshold X_{OFF} .

This is illustrated in Fig. 5.2. The threshold value is entered by the user for each channel individually.

When the linear outputs are in this mode, the "On" and "Off" signal levels are equal to the minimum and maximum output signal values for the given output. For example, if the output parameters are set to have a minimum output signal of 2.5 V and a maximum of 9.5 V, then the "Off" state will correspond to 2.5 V, and the "On" state will correspond to 9.5 V.

For key outputs, the on and off states correspond to 0 V and 15 V, respectively (for an active output).

5.6.1. There are two characteristics of the threshold signal - direct and inverse (see graphs in Fig. 5.2).

If the “direct” characteristic is set, then the output signal Y of the corresponding channel is formed based on the following conditions :

- if $X \leq X_{\text{OFF}}$, $Y = Y_{\min}$,

- if $X \geq X_{\text{ON}}$, $Y = Y_{\max}$

If the "inverse" characteristic is set, then:

- if $X \leq X_{\text{OFF}}$, $Y = Y_{\max}$

- if $X \geq X_{\text{ON}}$, $Y = Y_{\min}$.

Thus, in the mode of generating threshold output signals, when setting up the corresponding channel, it is necessary :

- select an informative parameter X
- enter the value of two thresholds – the on threshold and the off threshold.

Time can also be specified as a threshold. In this case, the output's on time ($Y = Y_{max}$) and off time ($Y = Y_{min}$) are specified (hours:minutes). One on time and one off time can be specified per day.

With a "reverse characteristic" the output signal changes to the opposite .

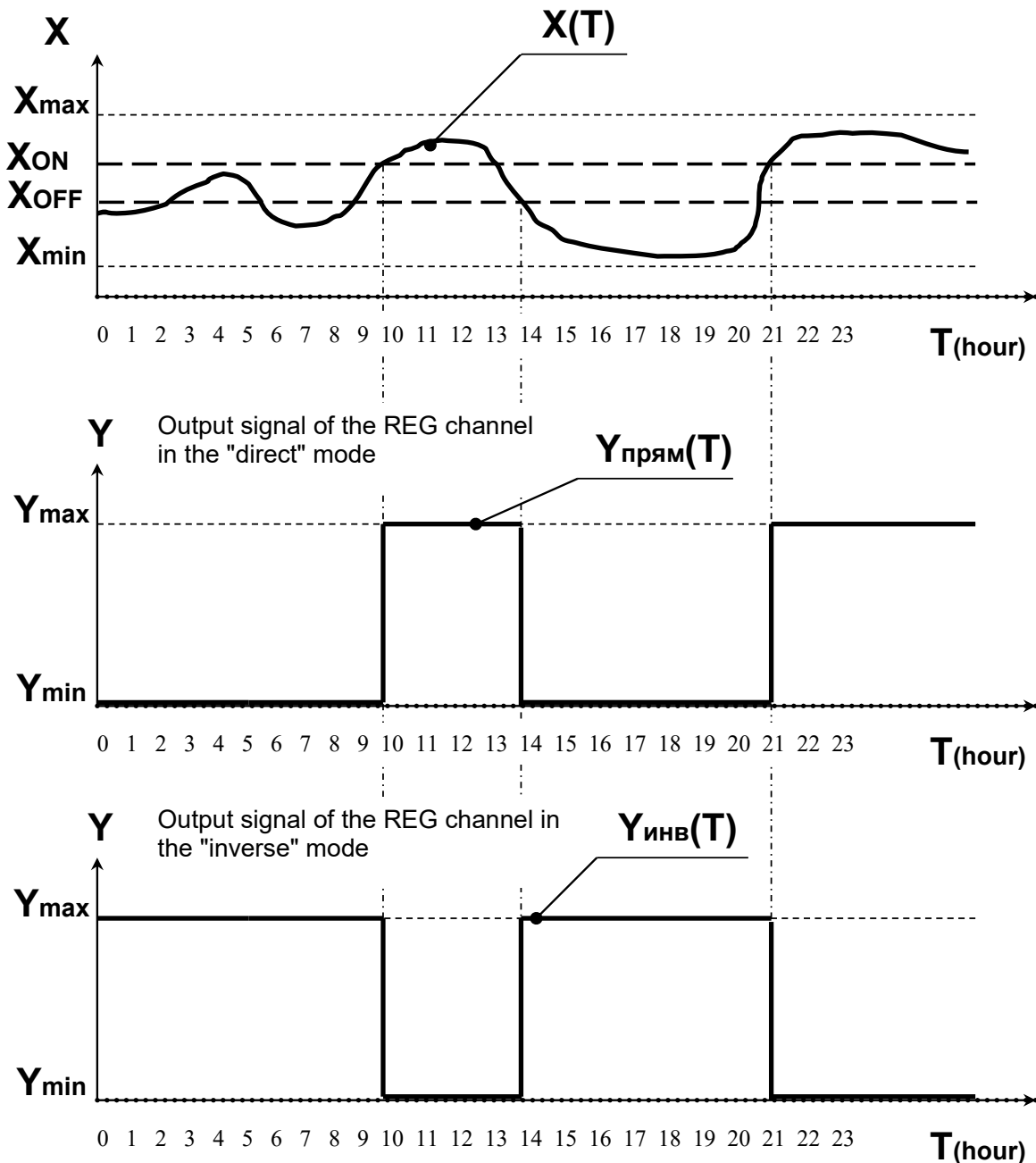

Fig. 5.2

5.6.2. Correction by external temperature.

For this output type, it is possible to set threshold correction values depending on the temperature of any of the RTDs. This mode is only available when using temperature as an information parameter.

To configure the correction, do the following:

- select the RTD for which the correction will be performed
- enter two characteristic points that define the correction graph

Each of the input points specifies a temperature value and a threshold shift value at that temperature .

An example of the correction of the on-threshold is shown in Fig. 5.3 (correction of the off-threshold is performed in a similar way):

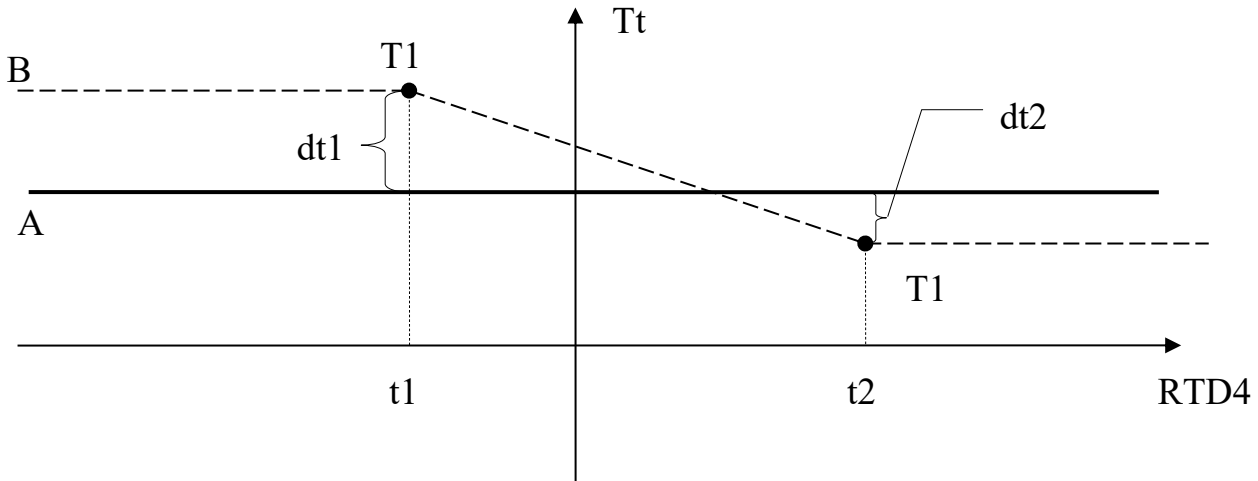

Fig. 5.3

Here the “A” line is the threshold value before correction (regardless of temperature dependence).

In this example, correction is performed based on the RTD4 value (X-axis). "B" is the threshold behavior with correction. Two correction points, "T1" and "T2," are specified. At each point, a temperature value (t_1 and t_2 , respectively) and a threshold value shift (dt_1 and dt_2 , respectively) are specified).

The threshold value in the interval between T1 and T2 points is described by the expression:

$$T_{TC} = T_T + T_C(t_n) \quad (5.3)$$

where T_{TC} is the calculated current threshold value used to control the output

T_T is current threshold value without correction

$T_C(t_n)$ is the value of the correction coefficient (bias) as a function of t_n temperature:

$$T_C(t_n) = \frac{dt_2 - dt_1}{t_2 - t_1} \cdot (t_n - t_1) + dt_1 \quad (5.4)$$

At temperatures below t_1 and above t_2 , the threshold shift will be equal to dt_1 and dt_2 , respectively.

5.7. «Regulator» output type

(generation of control signals for control valves).

Only for linear outputs.

5.7.1. The operation of the REG unit channel in the mode of generating output signals Y_i for controlling the control valves is explained by the structural diagram shown in Fig. 6.3. The values of temperatures T_1, T_2, T_3, T_4, T_5 measured by the meter in the i -th measurement cycle can be used as readings of the input information parameter X_i in the REG.

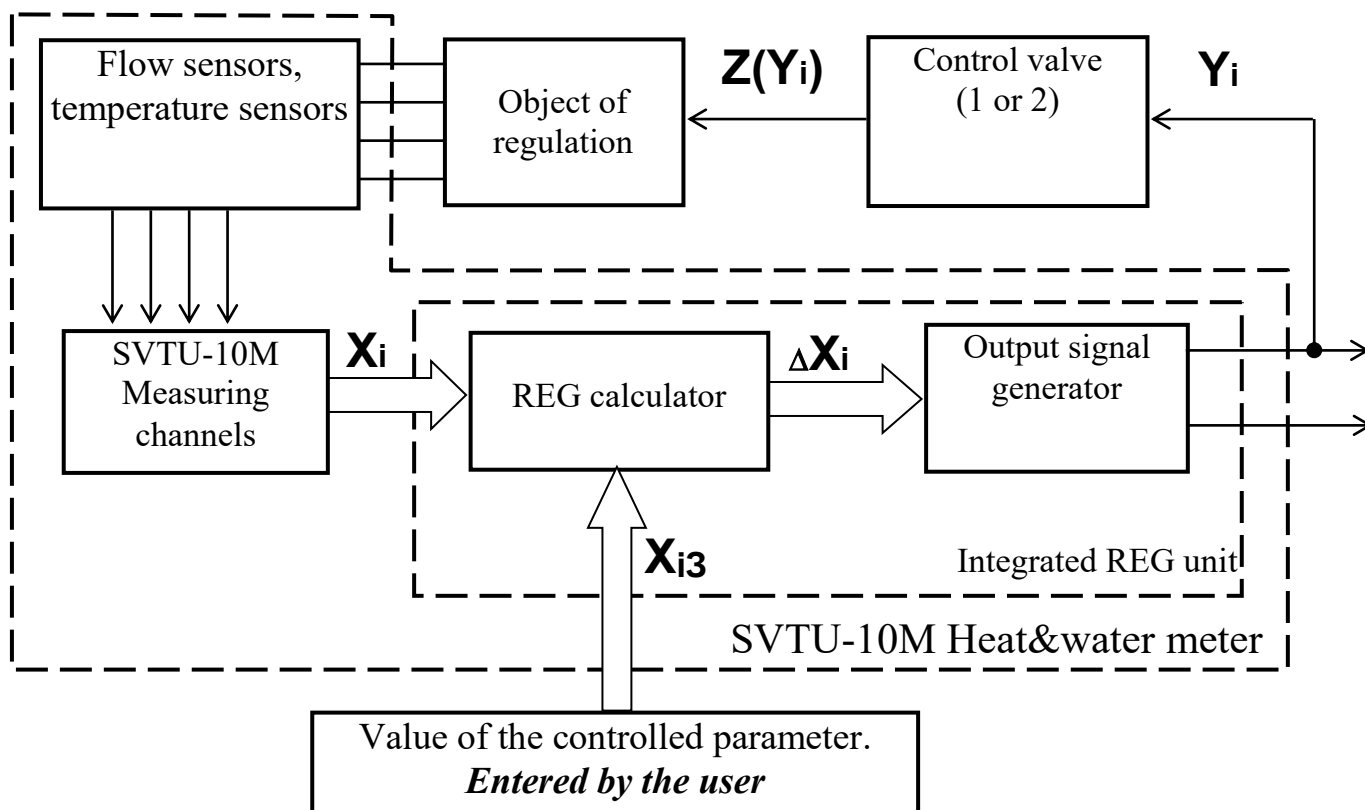

Fig. 5.4

5.7.2. When programming the corresponding channel for operation in the regulation mode, the user sets the value of the controlled parameter (hereinafter referred to as the setpoint) using the SVTU-10M meter keyboard (or with the help of a computer, using the “Sempal DM” program).

During operation, the regulator strives to maintain the controlled parameter equal to the setpoint value.

5.7.3. Based on the analysis of the ΔX_i value, equal to the difference between the actually measured values X_i and the set values X_{i3} , the value of the output signal Y_i of the control valve is formed. The control valve exerts an effect $Z(Y_i)$ on the control object in such a way as to reduce the ΔX_i value to zero (see the graph in Fig. 5.5).

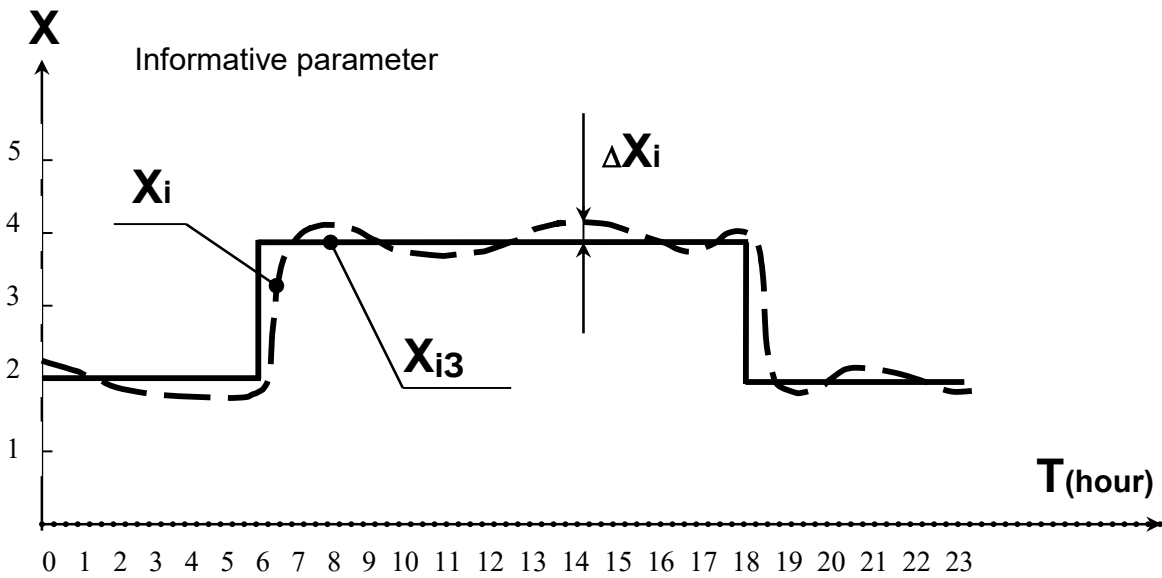

Fig. 5.5

5.7.4. The REG unit implements a proportional-integral control law. The output signal in the control mode of the control valves is described by the following expression :

$$Y_i = K \cdot \left(\Delta X_i + \frac{t_{ИЗМ}}{t_{РЕГ}} \cdot \sum_0^i \Delta X_i \right) \quad (5.5)$$

where K is user-defined controller gain;

$\Delta X_i = X_i - X_{si}$ is the difference between the value of the informative parameter X measured by the meter at the i -th moment in time (at the i -th measurement cycle) and the set-point X_{si} set by the user when configuring the REG channel;

$t_{ИЗМ}$ is data transfer cycle time in seconds ($t_{ИЗМ} = 1$ sec).

$t_{РЕГ}$ is user-defined controller time constant.

5.7.5. It is possible to choose from the following control algorithms:

- temperature;
- heat supply loop.

5.8. Setting

Two control schedules are implemented: hourly and weekly.

The hourly schedule operates within a 24-hour period. Up to four points can be set within a 24-hour period. To do this, a time (hour:minute) and a setpoint value are specified, which is applied when the specified time is reached. This schedule repeats periodically for each day.

The weekly control schedule allows you to define weekends and workdays within a week. For workdays, an hourly control schedule is used, while for weekends, a separately entered setpoint is used .

5.9. Temperature correction

To implement temperature correction of the currently active setpoint, any of the temperature sensors connected to the meter can be selected—the user chooses the desired one.

The temperature correction curve is defined by two characteristic points. At each point, a temperature value and a setpoint shift value are specified.

Fig. 5.6 shows an example of such a correction.

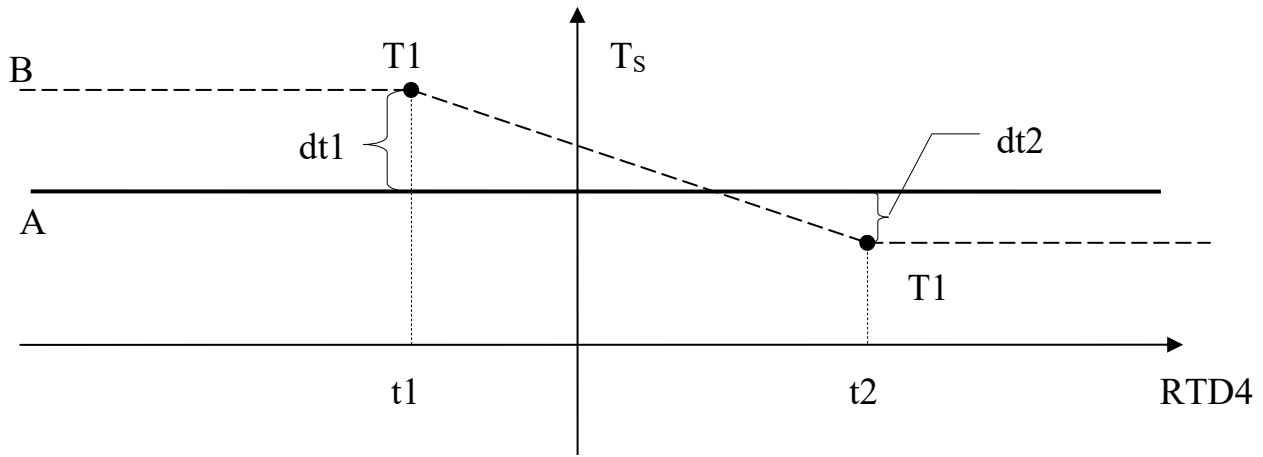

Fig. 5.6

Here “A” is the setpoint value without correction, “B” is the setpoint graph after correction.

The value of the setpoint in the interval between points T1 and T2 is described by the expression:

$$T_{SC} = T_S + T_C(t_n) \quad (5.6)$$

where T_{SC} is the calculated current setpoint value used for regulation

T_S is current setpoint value without correction (taking into account the hourly and weekly schedule)

$T_C(t_n)$ is the value of the correction coefficient (bias) as a function of temperature t_n :

$$T_C(t_n) = \frac{dt2 - dt1}{t_2 - t_1} \cdot (t_n - t_1) + dt1 \quad (5.7)$$

At temperatures below t_1 and above t_2 , the setpoint offset will be equal to dt_1 and dt_2 , respectively.

For example, a correction based on external temperature is set with the following parameters:

— point 1: $t_1 = -10 \text{ }^\circ\text{C}$, $dt_1 = +10 \text{ }^\circ\text{C}$

— point 2: $t_2 = +5 \text{ }^\circ\text{C}$, $dt_2 = -15 \text{ }^\circ\text{C}$

Let the outside air temperature be $-5 \text{ }^\circ\text{C}$. Then, using (5.7) we calculate the value

$$T_C = ((-15 - 10)/(5 - (-10))) \cdot (-5 - (-10)) + 10 = +1.7 \text{ }^\circ\text{C}.$$

Thus, if, for example, the initial setpoint value is $25 \text{ }^\circ\text{C}$, then the resulting setpoint value will be $25 + 1.7 = 26.7 \text{ }^\circ\text{C}$. That is, the regulator will maintain the temperature $T_{SC} = 26.7 \text{ }^\circ\text{C}$.

5.10. Temperature regulation.

In this mode, the temperature is regulated using a randomly selected temperature sensor connected to the meter.

Hourly and weekly regulation schedules are available, as well as a temperature correction schedule (it.5.9).

5.11. Heating regulation.

In this mode, two thermometers are used for regulation. The first one (T_{OT}) to regulate the temperature of the coolant (main control channel), the second one (T_{OBP}) to control the temperature of the return pipeline (auxiliary control channel).

Sensors of T_{OT} and $T_{OБP}$ the user arbitrarily assigns from those included in the meter delivery set.

Hourly and weekly schedules and temperature correction are applicable for the T_{OT} setting (it.5.9).

Additionally, the user can enter a schedule for the maximum temperature $T_{OБP}$, above which it ($T_{OБP}$) should not rise. The schedule for the maximum $T_{OБP}$ value is independent of the hourly and weekly schedules. To set the schedule, select the correction RTD and enter two schedule points, similar to it. 5.9. However, unlike paragraph 5.9, here the graph defines not the setpoint offset, but the maximum temperature value itself. That is, two points are entered, for each of which the temperature of the correcting RTD and the $T_{OБP}$. maximum value are specified.

Thus, in the "Heating" mode, the user sets the setpoint value for T_{OT} (hourly and weekly schedules) and the $T_{OБP}$ maximum temperature schedule, depending on an arbitrary temperature selected. In addition, the user can also set a T_{OT} correction depending on an arbitrary temperature (for example, the outside air temperature).

If during operation the temperature $T_{OБP}$ becomes equal to or exceeds the set maximum value ($T_{OБPмакс}$), the main control channel is switched off, and the temperature $T_{OБP}$ decreases until it becomes 2 °C less than $T_{OБPмакс}$. After this, control via the main channel is resumed - T_{OT} .

A similar algorithm is used if $T_{OБP}$ falls below 10°C. In this case, the $T_{OБP}$ temperature is raised to 12°C, after which regulation resumes.

5.12. In the REG unit, the user can set a direct or inverse control characteristic for each of the control channels (output setting parameter). A direct characteristic is set when an increase in the controller output signal Y_i leads to an increase in the value of the control parameter. Otherwise, a reverse characteristic is set.

5.13. The user can set the maximum valve closing percentage. This will prevent the valve from closing more than the specified value.

For example, if the closing threshold is set to 20%, the valve will never close more than 20%.

In manual valve control mode, this parameter is ignored.

5.14. When using REG to generate control signals for control valves, the user must enter the following information :

1) Set up the output signal generator for the corresponding controller channel (output 1 for control channel 1 and output 2 for channel 2):

- set the range of change of the output signal;
- select the output characteristic (forward/reverse);
- select the output type - "regulator".

2) Set up the regulator channel, for what:

- select the required channel;
- set the adjustable parameter;
- if regulation by T or $T_{OБP}$, is selected, set the RTD number by which regulation will be performed ;
- if heating regulation is selected, set the RTD number according to which regulation will be performed (for example, the temperature of the heating system), select the RTD for correction according to the outside temperature (if necessary), select the RTD of

the return pipe (if necessary) and select the RTD for setting the return pipe temperature limitation schedule (if necessary);

- set the value of the adjustable parameter and, if necessary, set the parameters of the hourly and weekly schedules;
- for the heating mode, set the correction parameters, if required;
- set the value of the time constant of the controller channel (c);
- set the value of the regulator channel transmission coefficient;
- set the minimum value of the valve closing percentage.

5.15. If the regulator mode is used, a manual valve control mode is provided for adjusting the control system. When entering this mode, the indicator displays the current state of the valve control signal as a percentage of the fully open state and the current value of the controlled parameter.

To control the valve position (see Appendix C) in manual mode, the "Up" and "Down" buttons are used. A single press of these buttons results in an increase or decrease (respectively) of the controller output signal by 5% relative to the value for a fully open valve.

If no buttons are pressed within 10 minutes, the REG exits this mode.

5.16. If no measurement data for the controlled parameter is received from the meter within 20 seconds (measurement error, ...), the REG sets the valve to the middle position.

5.17. All REG parameters can be set remotely via a computer using the "Sempal DM" program.

5.18. Warning!

When the meter is operating from the built-in backup power source, all unit outputs are switched off:

- potential linear outputs are set to 0 V;
- current linear outputs – in the 0 mA state;
- key outputs – in high-impedance state.

6. Preparing for operation

6.1. Connect the cables from external devices to the terminals of the switching unit. Appendix A provides a table for connecting devices to the switching unit.

6.2. Examples of connecting drives of the LR24A-SR, TR24-SR, SR24A-SR, NRY24A-SR, NV24-MFT, NVF24-MFT types manufactured by BELIMO are given in Appendix C .

The recommended drives are powered by a 24V AC or DC source. A 220/24V transformer with an 8-10 VA rating or an 8-10 W DC source can be used as an AC source.

6.3. Connect an external device.

6.4. Set the required configuration and parameters of the outputs and control channels in accordance with the customer's requirements.

An approximate methodology for evaluating the controller parameters is provided in Appendix D.

A description of the REG parameter setting menu is provided in Appendix C.

7. Manufacturer's warranties

Since the built-in REG unit is an integral part of the SVTU 10M heat water meter, it is covered by all warranties applicable to the SVTU 10M heat water meter, as specified in the operating manual.

Appendix A
Assignment of the switching unit terminals

Designation	Assignment
PulsOut1	Pulse output 1
PulsOut2	Pulse output 2
PulsIn1	Pulse input 1
PulsIn2	Pulse input 2
LinOut1	Linear output 1
LinOut2	Linear output 2
SwOut1	Key output 1
SwOut2	Key output 2
+15V	+15V power supply for pressure sensors
PressIn1	Output PS1 (pressure meter input 1)
PressIn2	Output PS2 (pressure meter input 2)
GND	Ground – common terminals for all signals. All GND contacts are connected together.

Example of connecting control valve drives

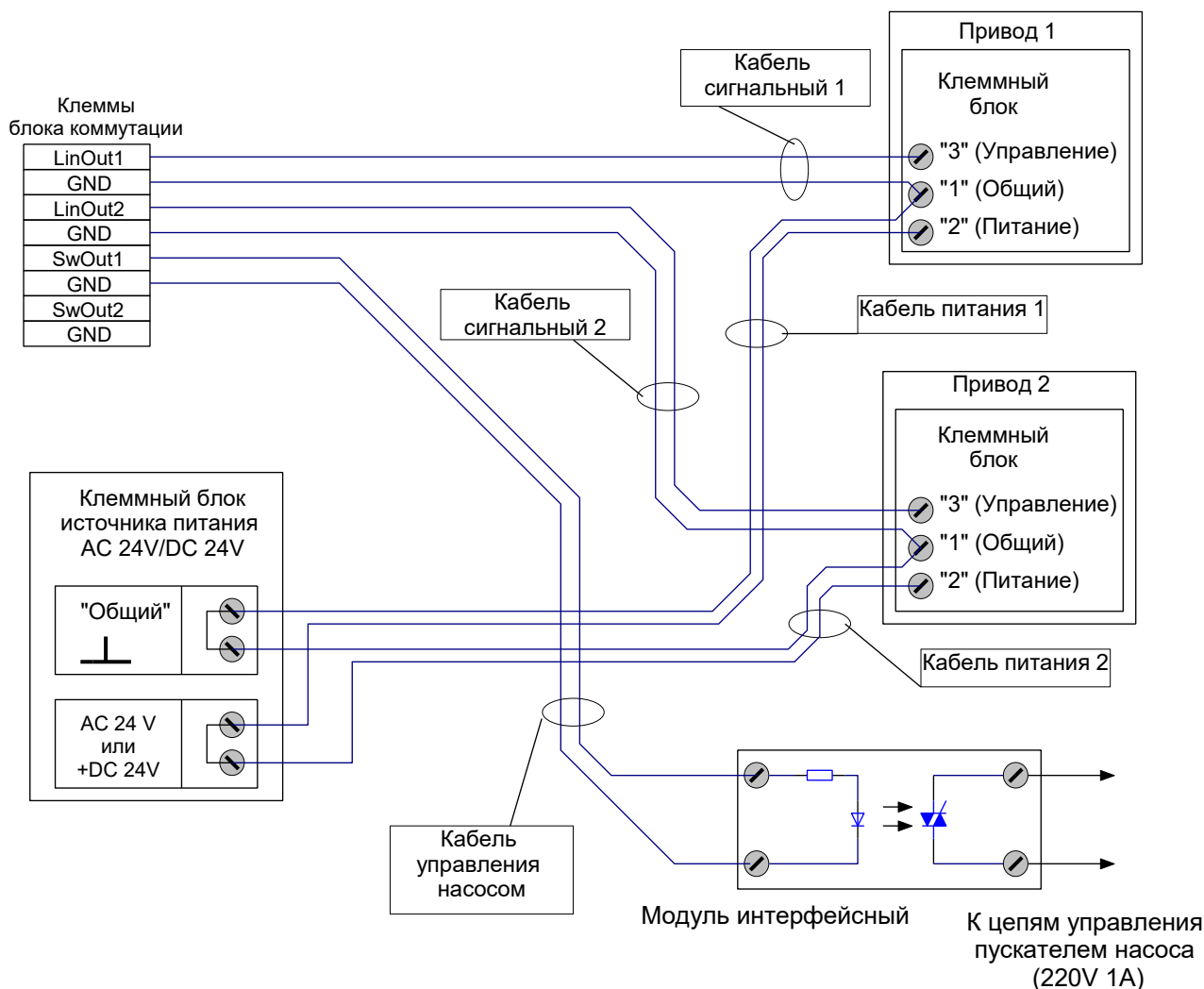

Note: This example is shown using LR24A-SR, TR24-SR, SR24A-SR, NRY24A-SR, NV24-MFT, and NVF24-MFT drives from BELIMO. When using other types of controllers, the input and output circuit assignments shown in the diagram must be taken into account. The PI6-1T-5...32VDC interface module from RELPOL is used as an example.

Description of the menu for setting up the parameters of the REG unit

The parameters of the REG unit can be set using the SVTU-10M meter keyboard or remotely via a computer (direct connection to the computer or via a modem) using the “Sempal DM” program.

The operation and purpose of the buttons are no different from those used when working in the menu of the SVTU-10M heat water meter.

When entering weekends, the following data entry algorithm is used. Days of the week from Monday to Sunday are represented as a seven-digit number, with each digit representing one day of the week. The leftmost digit is Monday, followed by Tuesday, and so on until Sunday. If the corresponding digit contains a 0, it is a weekday; if a 1, it is a weekend. Thus, entering a 1 in the corresponding digit designates that day of the week as a weekend.

Reference designation

These buttons have the following functions:

 - «Right»,  - «Up»,  - «Down»,  - «Left»

 → Move to next item if corresponding button has been pressed («Right» in the case)

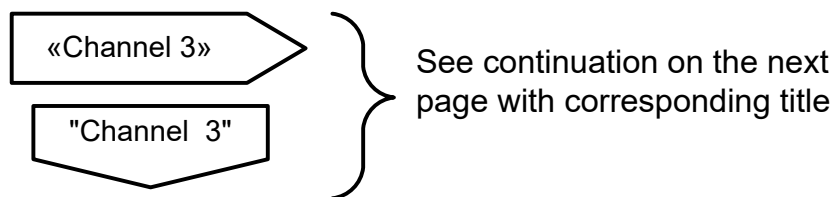

Menu item denoted as (*****) are indicated only for corresponding meter configuration.

Indication of menu item

t3
123.56 °C

Indicator in basic work mode.
The type of parameter and its dimension are displayed.

1.3. Mass channel 1
12345678 t

Indicator in menu item select mode.
Top line shows number of menu item and its name.
Bottom line can be used to display value of indicated parameter.

Editing of parameter can be done in three following steps:

- indication of parameter current value;
- editing the parameter. To start editing press “Right” button;
- indication of the result after ending of editing process.

After pressing the button “Right” edited symbol begins to blink.

There are two editing modes:
- **editing of digital value;**
- **select an item from the list.**

Editing of digital value

Edited digit blinks. Change of digit is provided by buttons “Up” and “Down”. Move to the next digit is provided by button “Right”. After reaching the last right digit the cursor moves to the first digit. Ending of editing occurs at pressing “Left” button. After that blinking is stopped and saved parameter value is displayed. If number with floating point are edited the final number may differ from entered number on one lower order bit. It can be explained by way of internal data representation.

3.3.2.1 PS1 Iout0
04.00 **mA**

Selection of the variant

Selecting menu item for change of parameter from the list of available values in the top row (right side) the current parameter value put into symbols “_” is indicated. After pressing “Right” button these symbols are changed to «▶ ◀» what means the beginning of editing. Change of parameter value is provided by “Up” and “Down” buttons. End of editing is occurred by “Left” button. After that entered value is displayed.

3.9.5 Puls out2 _chan 2_

If parameter shouldn't be edited (for example, “Enter” button has been pressed by mistake) editing can be interrupted and parameter would be in initial condition. For this purpose “Right” and “Left” buttons should be pressed simultaneously.

Notes:

1. Holding any button for more than 0.5 sec will result in autorepeat of that button with the rate of 3 times per second.
If there was no pressing buttons in 2 min, the meter switches from selection mode or password entry to “Indication of main parameters” mode.
2. If entered an invalid parameter, the meter displays an error message. Pressing any button clear error message and returns to previous menu.

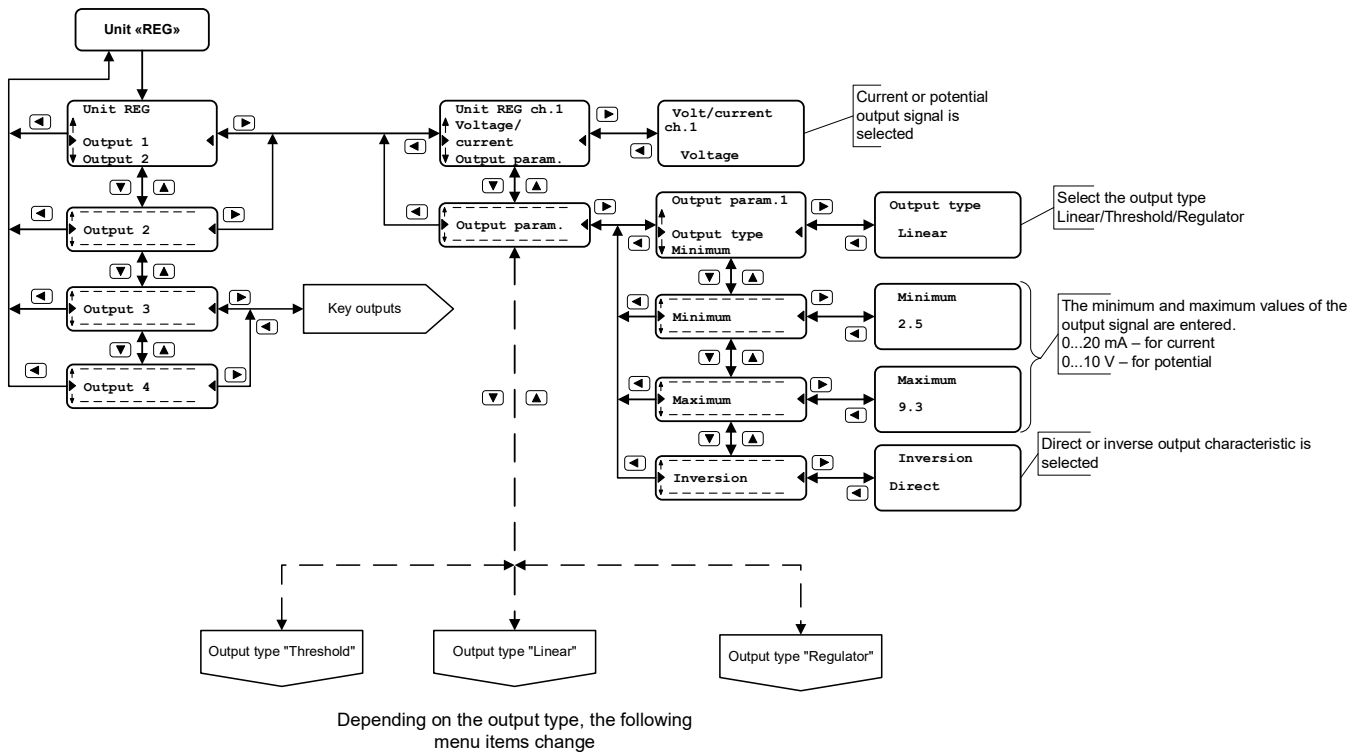

For «Linear» output type

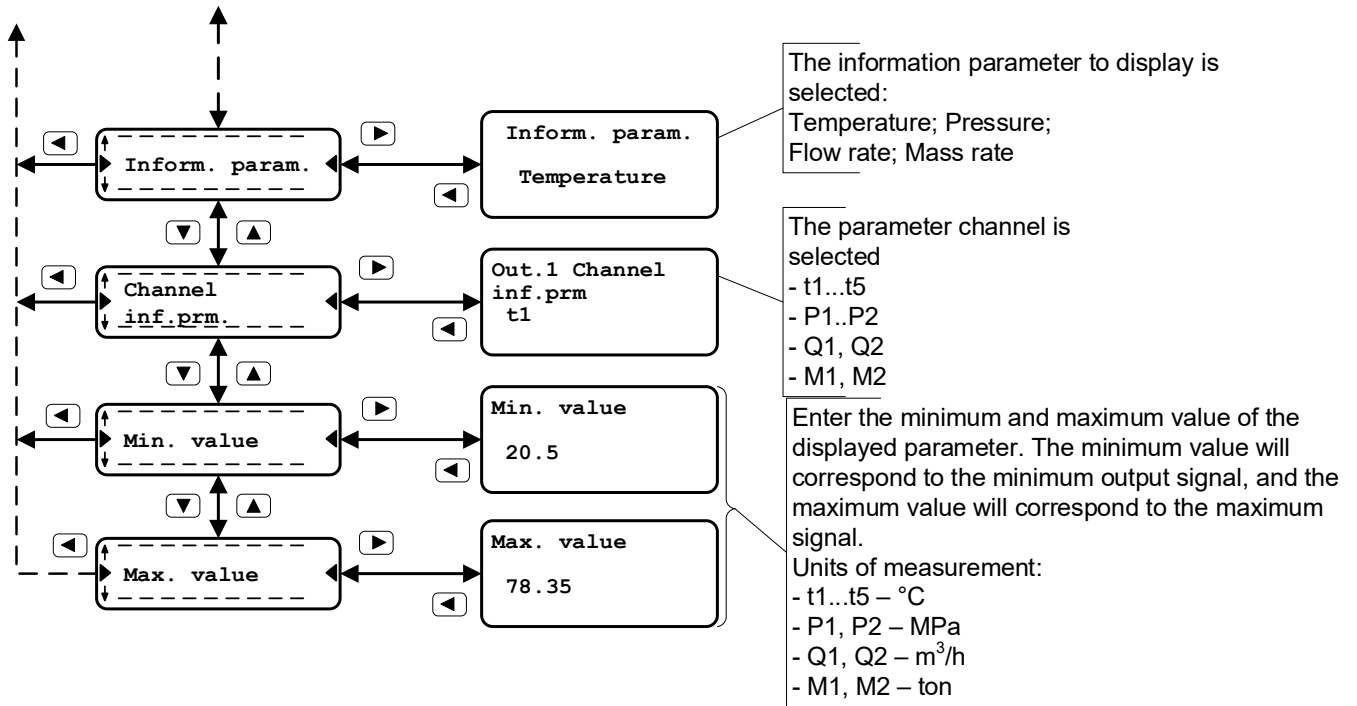

For «Threshold» output type

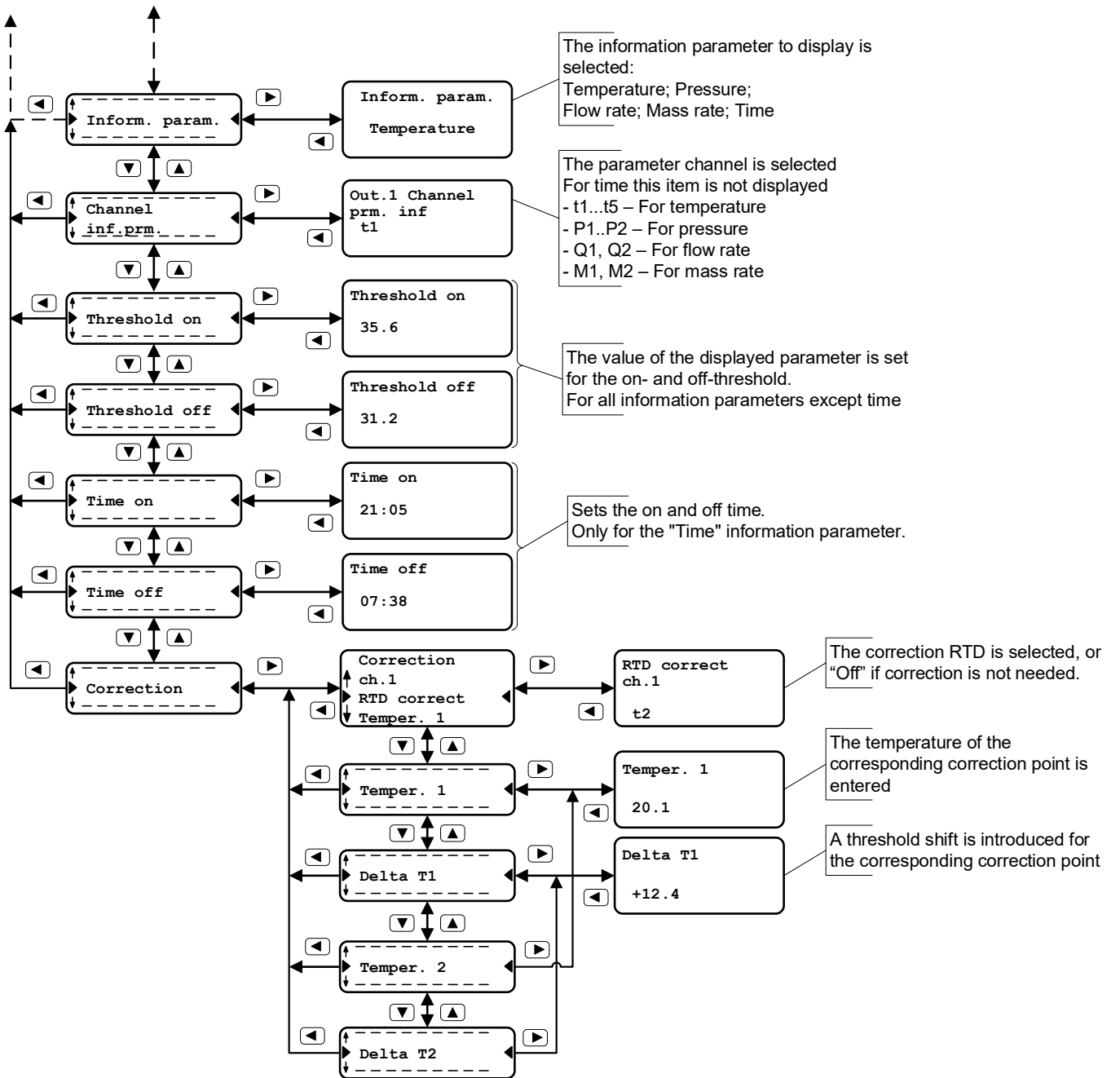

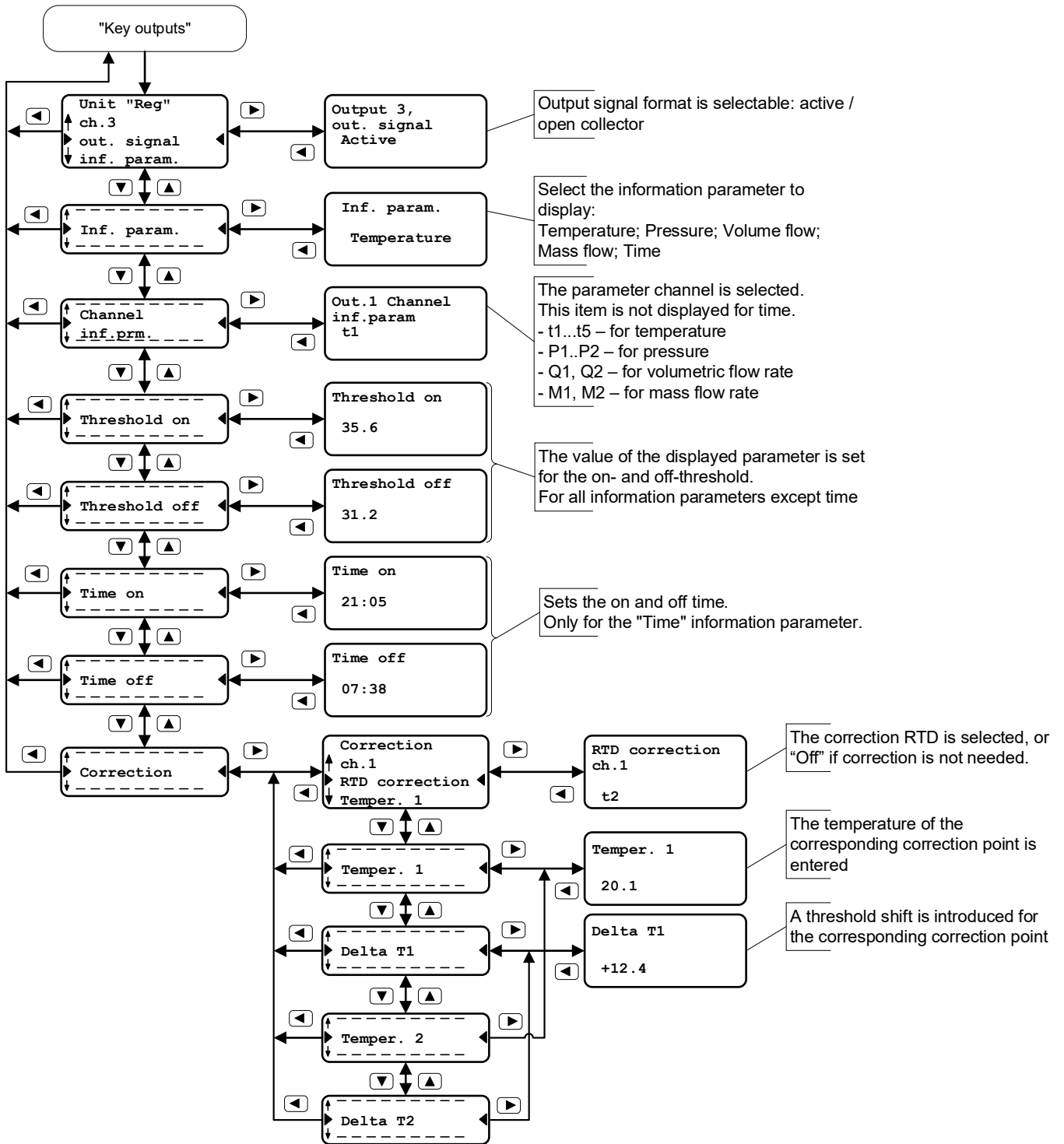

For «Regulator» output type

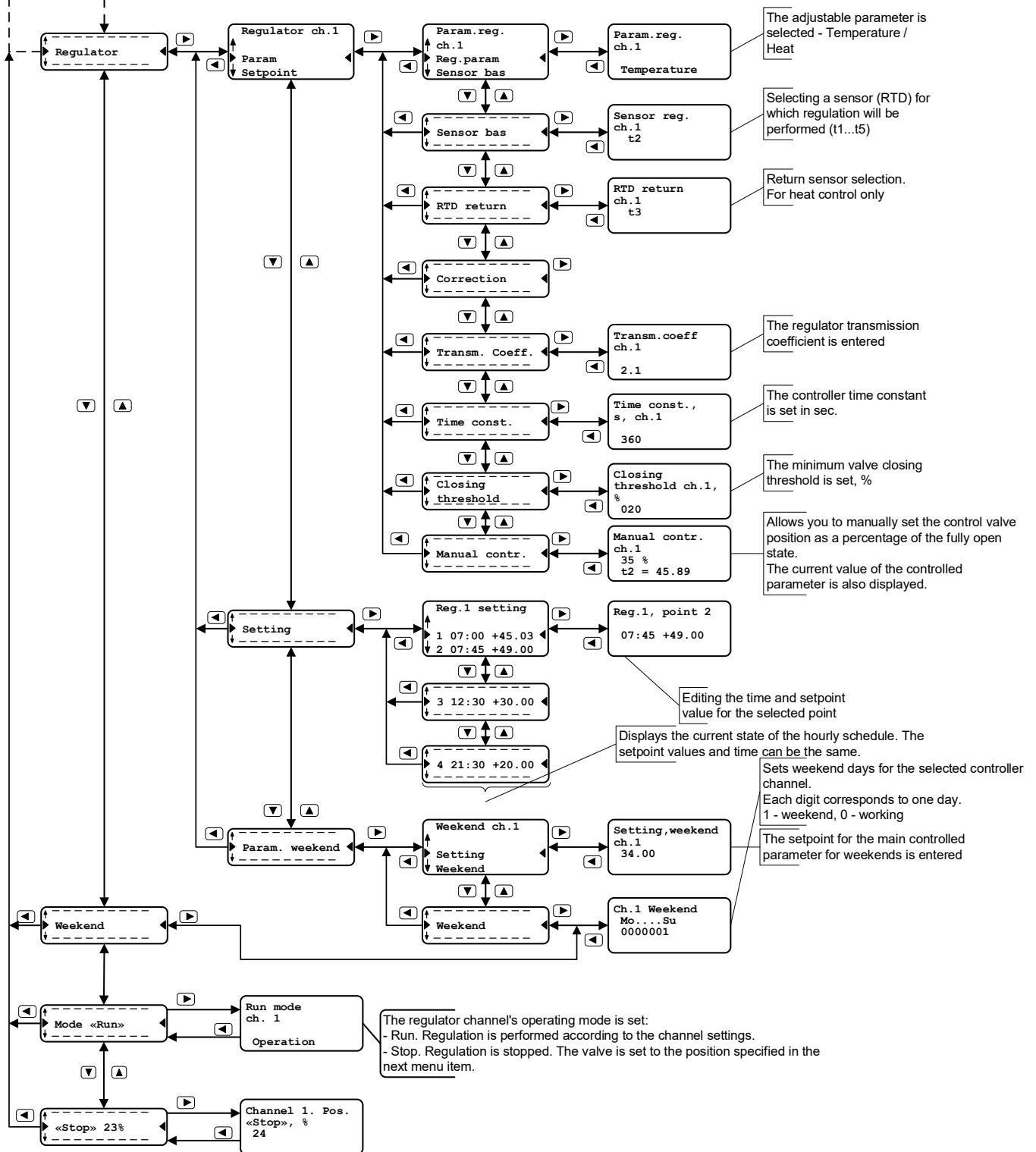

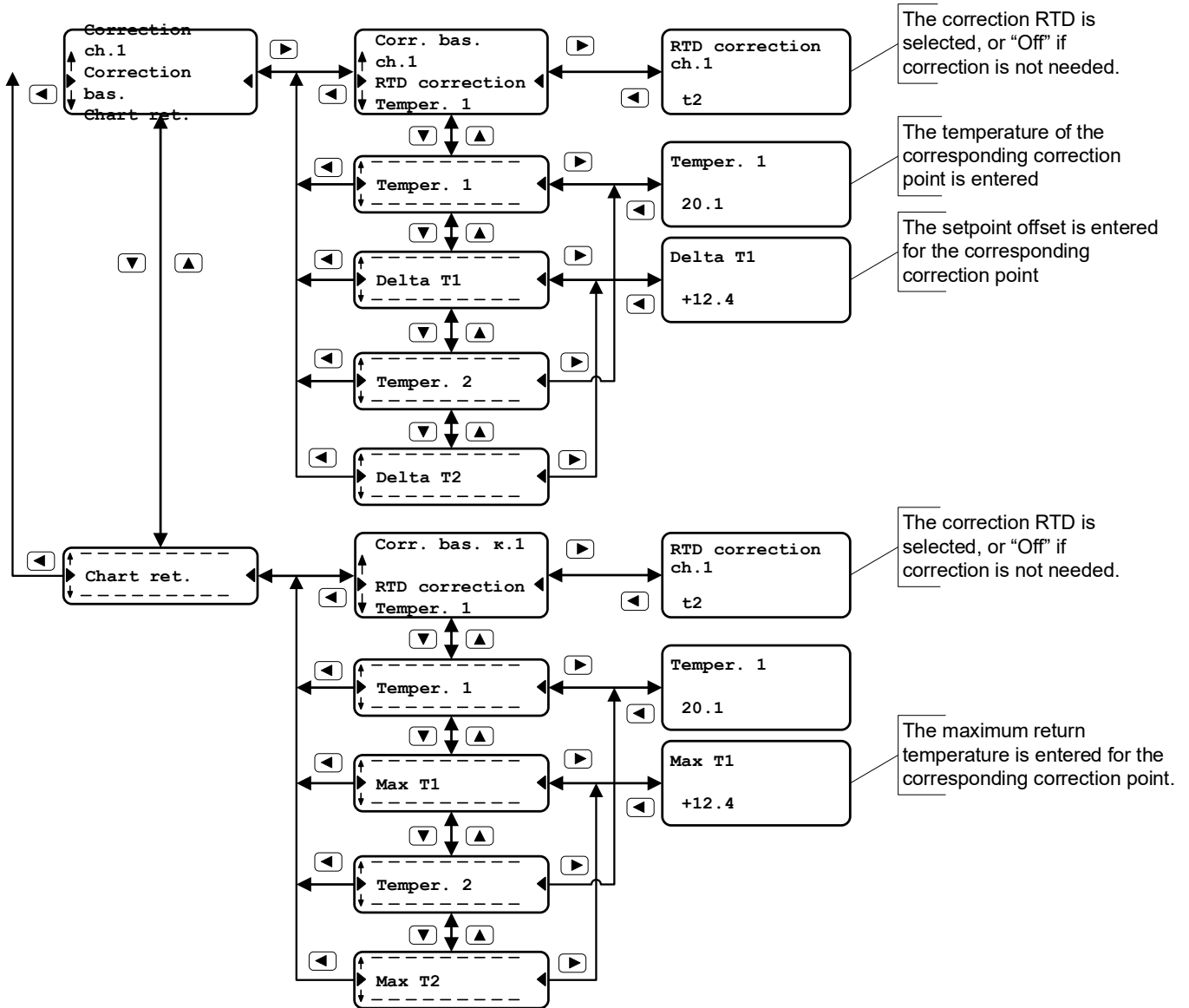

Methodology for assessing controller parameters

Below is a methodology for evaluating the controller parameters when regulating temperature.

The calculation of control parameters is carried out on the basis of data obtained when taking characteristics of the control object, and is performed according to the following algorithm.

1. Set the valve to the P_H position, at which the T_H temperature will be close to the maximum, but slightly lower (so that the temperature is determined by the valve position, not by the limiting washers). Fix the valve position, assuming that a fully open valve corresponds to a value of 1, and a fully closed valve corresponds to a value of 0.

2. Set the valve to the P_{MIN} position, at which the temperature in the system is slightly higher than the minimum T_{MIN} , and fix the valve position.

3. Calculate the temperature T_0 by the formula:

$$T_0 = 0.03 \cdot (T_H - T_{MIN}) + T_{MIN}$$

4. Set the valve to the P_H position and start the stopwatch. Record the time t_0 until the temperature reaches the T_0 value, and without stopping the stopwatch, continue monitoring the temperature.

5. Record the time t_H until the temperature in the system reaches the value $T_H - 0.03 \cdot (T_H - T_{MIN})$.

6. The graph of the object's temperature change should look approximately as shown in Fig. D.1.

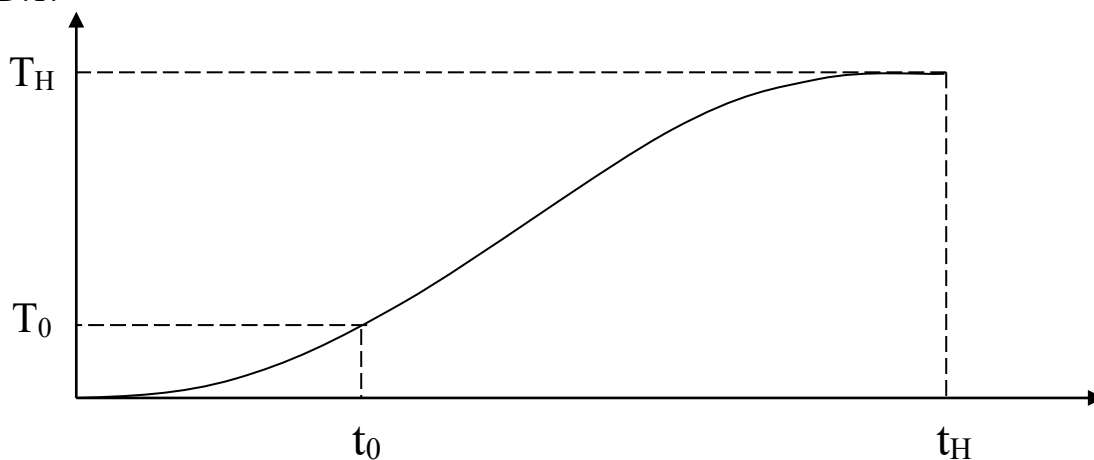

Fig. D.1

7. Calculate the transfer coefficient K and the time constant t_{per} for entering into the controller using the formulas:

$$K = 0.8 \cdot 160 \cdot \frac{P_H - P_{MIN}}{T_H - T_{MIN}}$$

$$t_{per} = 0.7 \cdot \frac{t_H - t_0}{4.5}$$

where the numerical values T_H and T_{MIN} are substituted in degrees, and t_H and t_0 are substituted in seconds.

The calculated values are entered into the controller.

During the process of debugging the control system, it is possible to change the above parameters to improve control quality. However, increasing the time constant slows the controller's response to external influences, meaning the controller will not handle short-term temperature surges. A significant reduction in the time constant (more than 2 times) can lead to a loss of system stability, resulting in undamped oscillations. The transmission coefficient can be varied within the range of $\pm 30\text{...}40\%$. Reducing the transmission coefficient makes the controller's response to the input step smoother (without overshoot), but also slower. Increasing the transmission coefficient accelerates disturbance processing. However, overshoot occurs. Excessive increase in the transmission coefficient leads to increased process oscillation and, ultimately, to a loss of stability.

Figure D.2 shows the system's response to an input step at different transmission coefficients.

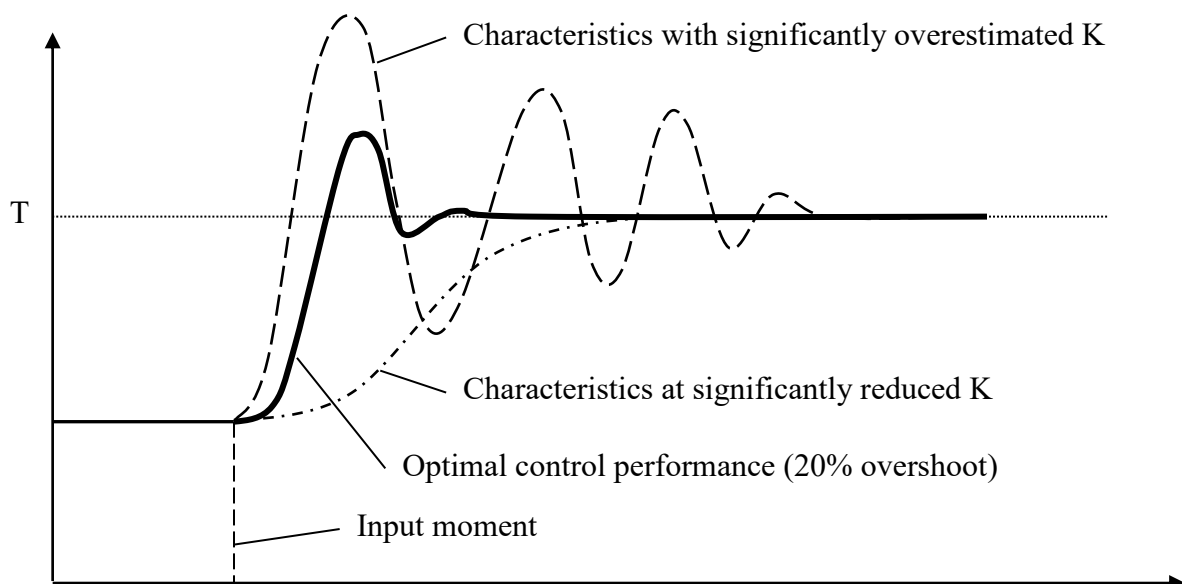

Fig. D.2

Example of parameter calculation

1. Let's say we have determined that the temperature of the object should be 30 °C and this temperature can be obtained by setting the valve to position 0.7 from the maximum open state.

2. Set the valve to the minimum allowable open position and allow the system to stabilize. Let's assume that the object temperature is 10°C and is reached with the valve position at 0.2 of the maximum.

3. Calculate the temperature T_0 :

$$T_0 = 0.03 \cdot (30 - 10) + 10 = 10.6 \text{ °C}$$

1. Open the valve to a position 0.7 from its maximum opening and start the stopwatch. As soon as the object's temperature exceeds 10.6°C, record the stopwatch time and continue monitoring.

2. We wait until the temperature of the object exceeds $30 - [0.03 \cdot (30 - 10)]$ °C, that is 29.4 °C.

3. Record the time T_H . Let's say we got the following times:

$$T_0 = 30 \text{ s and } T_H = 900 \text{ s.}$$

4. We calculate the transmission coefficient and time constant for entering into the controller.

$$K = 0.8 \cdot 160 \cdot \frac{0.7 - 0.2}{30 - 10} = 3.2$$

$$t_{per} = 0.7 \cdot \frac{900 - 30}{4.5} = 135$$

Thus, the transmission coefficient is 3.2, and the time constant for entering into the controller is 135 s.

Examples of control schemes

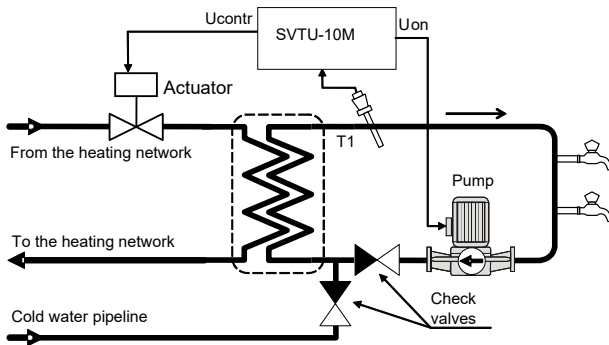

Fig.1 Temperature regulation in the Heat Water supply circuit

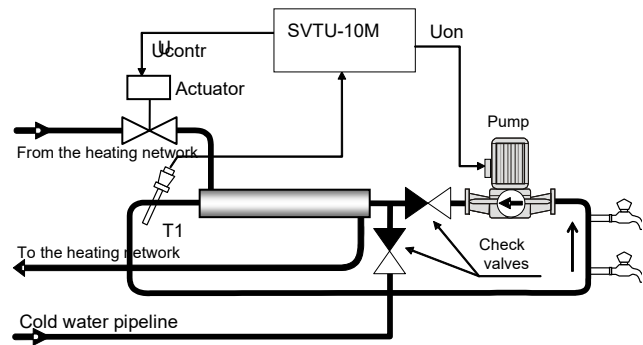

Fig.2 Temperature regulation in the Heat Water supply circuit

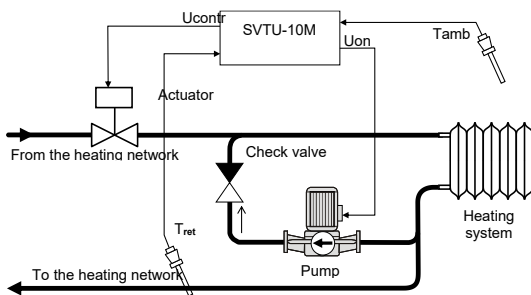

Fig.3 Temperature control at the outlet of the heating circuit with correction according to T_{amb}

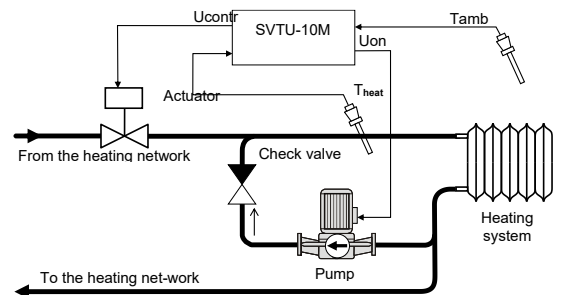

Fig.4 Temperature control at the inlet of the heating circuit with correction according to T_{amb}

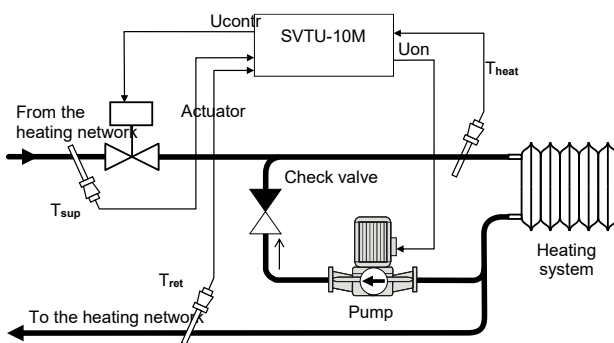

Fig.5 Temperature control at the inlet of the heating circuit with limitation of the return temperature

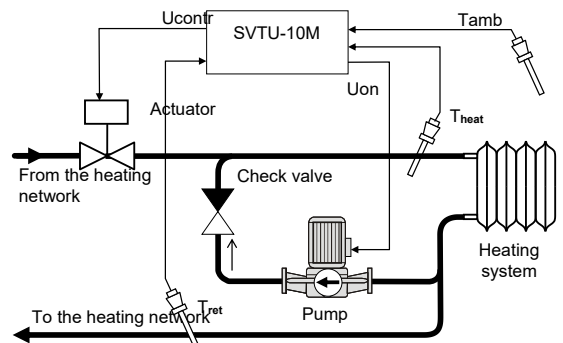

Fig.6 Temperature control at the outlet of the heating circuit with correction according to T_{amb}

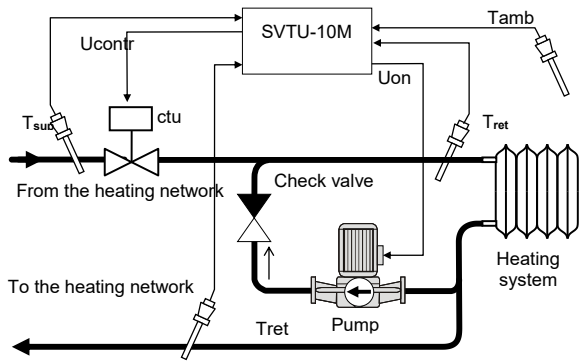

Fig.7 Temperature regulation at the heating circuit inlet with correction according to T_{amb} and return temperature limitation

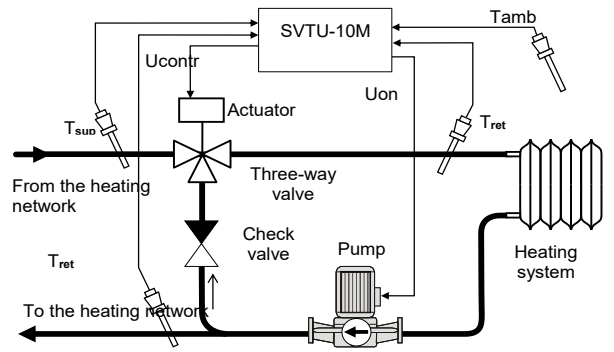

Fig.8 Temperature regulation at the heating circuit inlet with correction according to T_{amb} and return temperature limitation